

Design Potential Realised



With over 30 years of experience our expertise allows projects to be designed, developed, engineered and implemented to the highest standard and as an experienced system integrator the road from design to realisation is a smooth one.

Advantages

- ◆ Using high end design tools and expertise we can ensure the entire system integration is planned to the greatest detail, from baseband to antenna installation **and everything in between!**

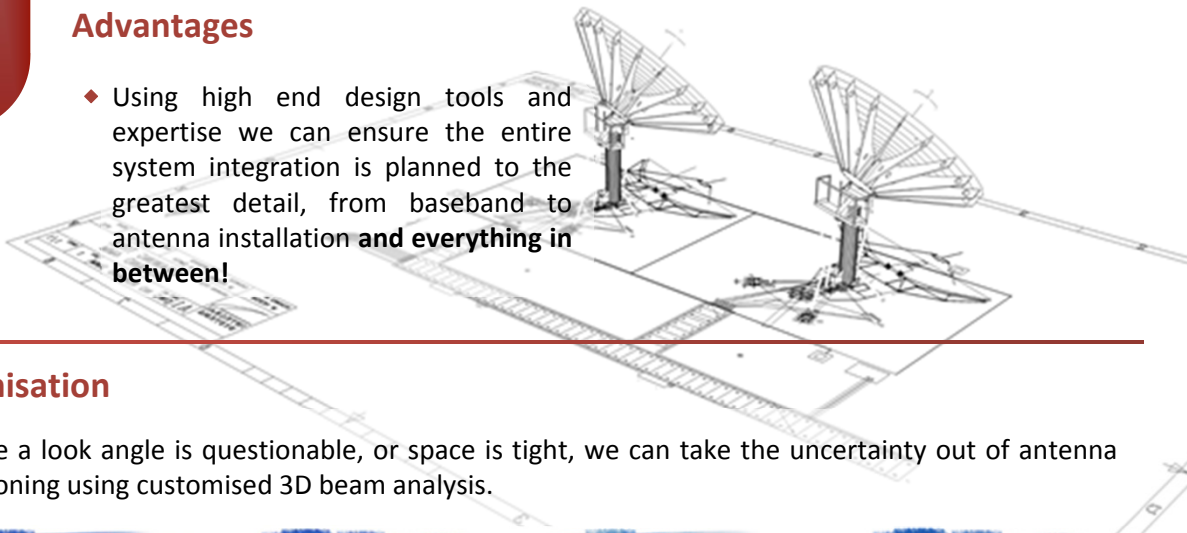

Customisation

- ◆ Where a look angle is questionable, or space is tight, we can take the uncertainty out of antenna positioning using customised 3D beam analysis.

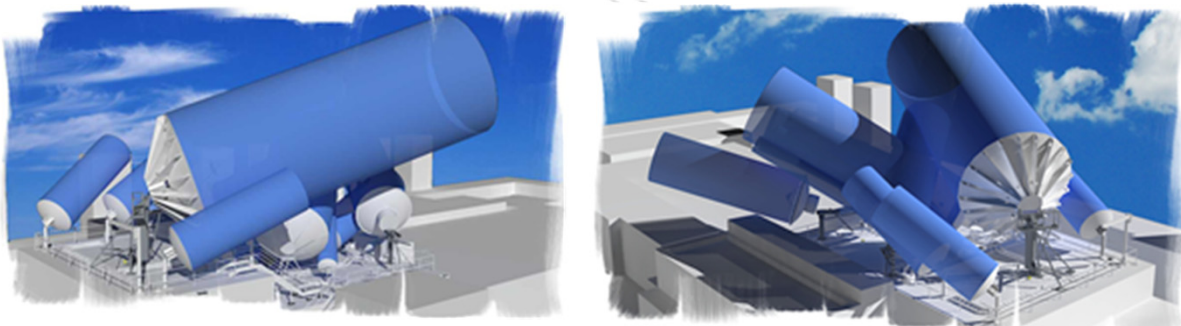

Our Goal

- ◆ Working with our customers we create a system design that is tailored and moreover a design that works through to implementation.
- ◆ We go the extra mile to make a design a reality.

The Entire Package....

Our expert team offers the complete detailed engineering, procurement and management of a turn-key project. Working to a specification or guiding our customers throughout the process. A brief summary of the services we can offer as part of the overall system is included below.

Power Systems

- ◆ From specification to installation we can offer what is needed to make sure your system is kept operational while remaining protected. Our skilled design team works closely with our suppliers to provide innovative up-to-date solutions to our clients together with customised solutions.



HVAC And HPA Cooling

- ◆ With a wealth of experience in cooling system design for High Power Amplifiers our team is well equipped to ensure our cooling systems are fit for purpose. We are well versed with air-con specification and working with our subcontractors for cooling in equipment rooms, shelters and even cooling of antenna hubs!



Equipment Cabins

- ◆ Our shelter design is well tested in harsh environments. Equipment shelters can come fully equipped with electrical system, Air conditioning systems, fire detection/protection, external lightning protection and fixtures and fittings as required.



Fire Systems



- ◆ Our shelter or equipment room design can include for fire system accommodation typically utilising the FM200 protection system.
- ◆ In addition we have existing solutions for HPA air duct operation allowing motorised air dampers to route HPA air internally to the equipment room in the event of a fire alarm to increase the FM200 systems effectiveness.